

# RF RGB Wall Mounted Controller

09.2830R.04197



**Important:** Read All Instructions Prior to Installation

## Function introduction

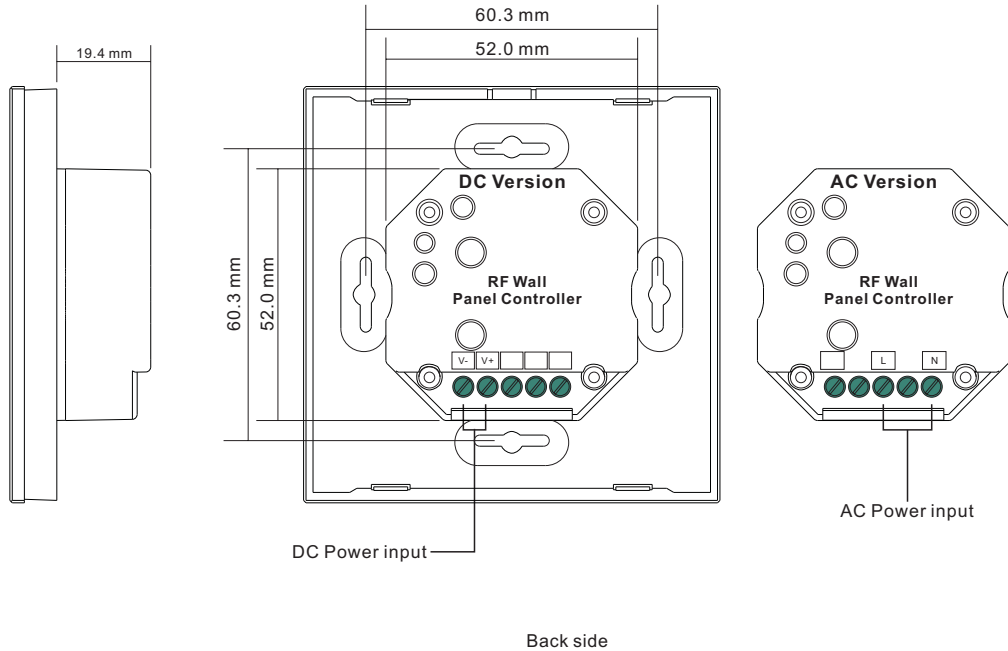
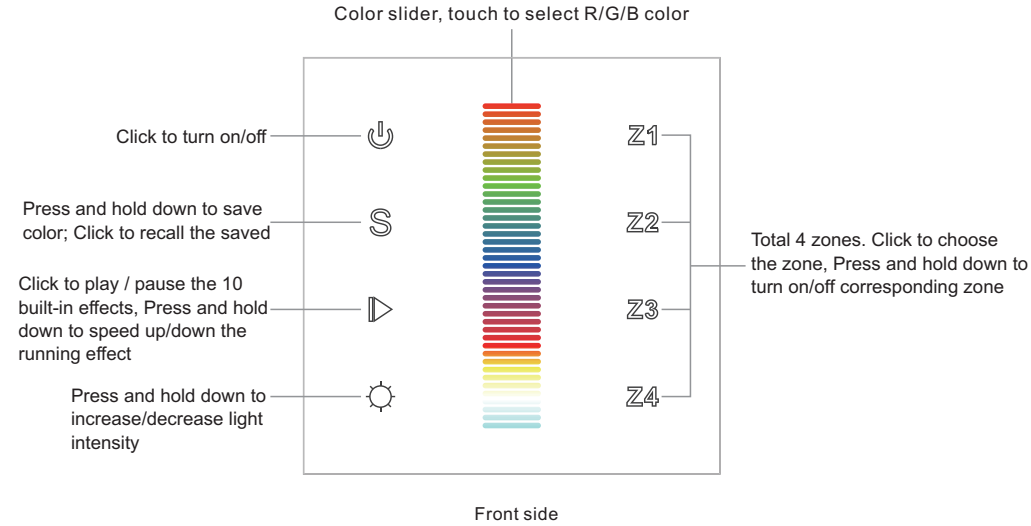

## Product Data

	DC Version	AC Version
Output Signal	RF signal	RF signal
Power Supply	12-24VDC	100-240VAC
Power consumption	200 mA	15 mA
Operating temperature	0-40°C	0-40°C
Relative humidity	8% to 80%	8% to 80%
Dimensions	86x86x29.1mm	86x86x29.1mm

- Touch sensitive
- Glass interface(white & black)
- Compatible with all universal series RF receivers
- Control RGB color
- Control 4 zone of RF receiver synchronously and separately
- Waterproof grade: IP20

## Safety & Warnings

- DO NOT install with power applied to device.
- DO NOT expose the device to moisture.

## Wiring diagram

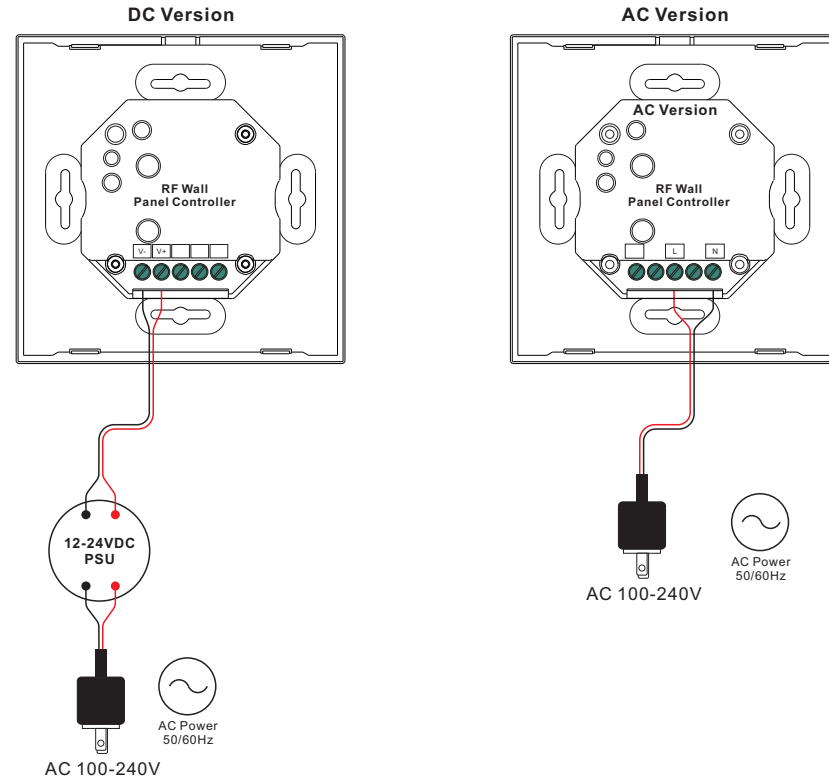

## Operation

### Pair with RF receivers:

Turn on the wall panel controller → Click "Learning Key" on RF receiver → Click a zone number :Z1-Z4 on the wall panel controller → Touch the color slider

→ LED lights connected with the RF receiver will flicker once → The receiver is paired with the remote successfully.

### Play the remote after pairing:

Turn on the wall panel controller → Click the paired zone number/numbers → Touch color slider or other buttons to do the controlling.

### How to delete the pairing:

Press and hold down "Learning Key" on the receiver for over 3 seconds until connected LED lights flicker twice, which means the pairing is deleted successfully.

## Installation

